

Subduction Zones & Tsunamis

Grades
5-8

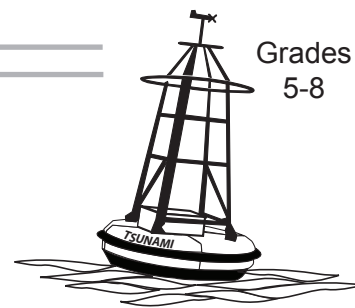

Overview:

In this lesson, students create a model of a subduction zone and explain how subduction zone earthquakes generate tsunamis.

Targeted Alaska Grade Level Expectations:

Science

[5-8] SA1.1 The student demonstrates an understanding of the processes of science by asking questions, predicting, observing, describing, measuring, classifying, making generalizations, inferring, and communicating.

[7] SD2.2 The student demonstrates an understanding of the forces that shape Earth by describing how the movement of the tectonic plates results in both slow changes (e.g., formation of mountains, ocean floors, and basins) and short-term events (e.g., volcanic eruptions, seismic waves, and earthquakes) on the surface.

Writing

[5] 2.1.3 The student writes about a topic by organizing ideas logically to establish clear relationships within and between paragraphs (e.g., using transition words or phrases that reveal order or chronology) (L)

[6] 2.1.3 The student writes about a topic by organizing and sequencing ideas logically to establish clear relationships within and between paragraphs (e.g., using transition words or phrases that reveal order or chronology, comparison/contrast) (L)

[7-8] 3.1.3 The student writes about a topic by organizing ideas using appropriate structures (e.g., chronology order, order of importance, comparison and contrast) to maintain the unity of the composition with a variety of transitional words and phrases.

Objectives:

The student will:

- create a model of a subduction zone;
- identify components of a subduction zone; and
- explain how subduction zones generate tsunamis.

Materials:

- Glue
- Scissors
- STUDENT WORKSHEET: "Subduction Model Templates"
- STUDENT WORKSHEET: "Subduction Zones"
- VISUAL AID: "Subduction Zone Tsunamis"

Science Basics:

Subduction zones form at convergent boundaries of lithospheric plates with different densities. Oceanic crust is thinner yet more dense than continental crust, therefore it subducts under the lighter plate. This action creates a trench along the boundary. As the subducting plate bends downward, it extends into the asthenosphere, the soft, jelly-like layer of the mantle, and melts. This is called the zone of melting. Above this zone the magma moves toward Earth's surface and forms volcanoes. As the plates move, stress builds along the plate margins of the subducting plate and the overriding plate. When this stress releases, earthquakes occur. Subduction zone earthquakes can be very strong. Sometimes they are strong enough to displace enough water to generate a tsunami.

Activity Procedure:

Create a model of a subduction zone using the templates provided on the STUDENT WORKSHEET: "Subduction Model Templates," as an example for student reference.

Activity Procedure:

1. Explain students will make a model of a subduction zone. By the end of the lesson they should be able to identify components of a subduction zone and explain how subduction zones generate tsunamis.
2. Show the example of a model subduction zone. Distribute a glue stick, scissors, and the STUDENT WORKSHEET: "Subduction Model Templates" to each student to make his or her own models.
3. After students have completed their models, write the following words on the board: continental crust, oceanic crust, plate margin, trench, volcano, and zone of melting. These are parts of a subduction zone. Explain how the subduction zone operates using the information from Science Basics. After the explanation, call out terms from the board and ask students to point them out on their models.
4. Display the VISUAL AID: "Subduction Zone Tsunamis," and use it to explain how earthquakes occurring along subduction zones may generate tsunamis.
5. Write transition words on the board. Explain these are words or phrases that can be used to link ideas.

Transition words that show sequence, or give order to ideas: *first, second, third, then, next, after, last, before, finally.*

Transition words that show cause and effect: *as a result, because, consequently, due to, leads to, therefore, thus.*

Call on students to use the information from the visual aid to make statements that include transition words. Model use of any challenging transition words.

Critical Thinking: Concentric Circles. Students stand in two concentric circles. They rotate to face new partners and share information asked by the teacher.

Topics: 1. Explain how the subduction zone works. 2. Explain how subduction zone earthquakes generate tsunamis, and encourage use of transition words.

7. Distribute the STUDENT WORKSHEET: "Subduction Zones" for student completion.

Extension Idea:

- Color the model prior to cutting and gluing the pieces together.

Answers:

1. Refer to diagram at right.
2. Student responses should chronologically explain information described on VISUAL AID: "Subduction Zone Tsunamis" and include transition words or phrases.

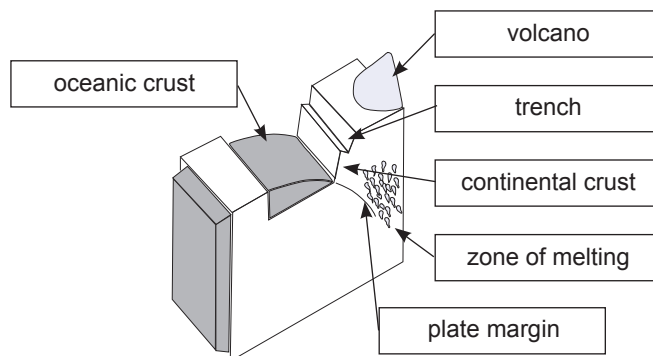

Name: _____

Subduction Model Templates

Student Worksheet (page 1 of 3)

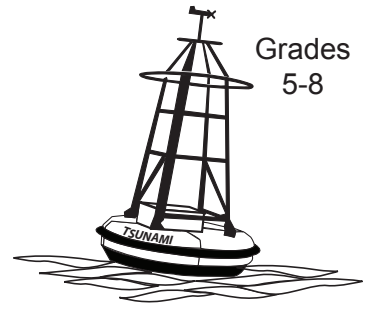

You will need scissors and glue. The finished ocean trench model should look like this.

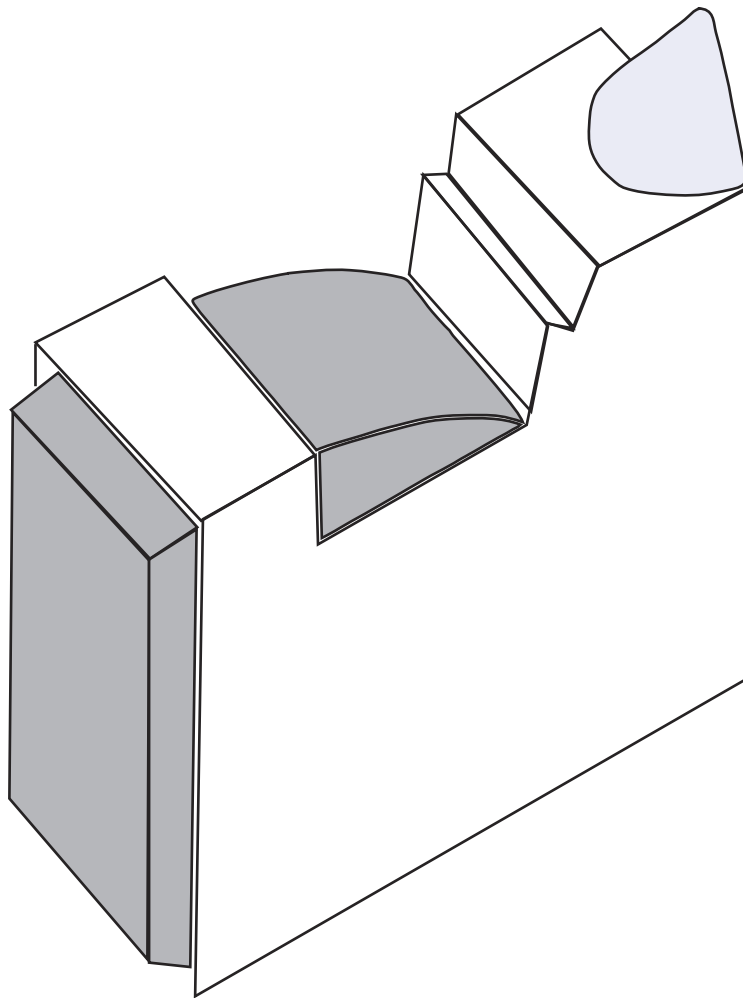

Ocean trench model designed by Tau Rho Alpha and John P. Galloway, U.S. Geological Survey.

Subduction Model Templates

Student Worksheet (page 2 of 3)

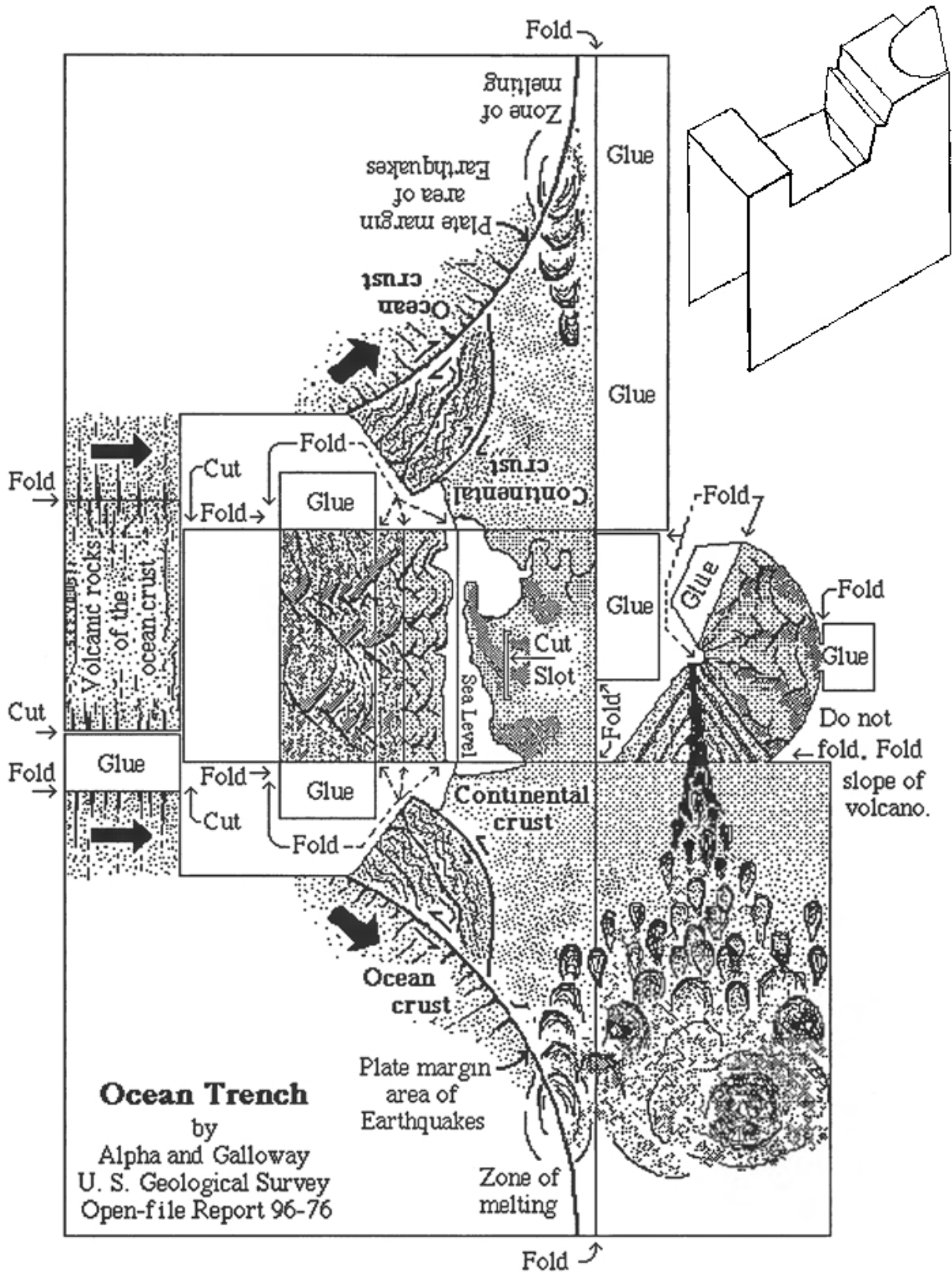

Subduction Model Templates

Student Worksheet (page 3 of 3)

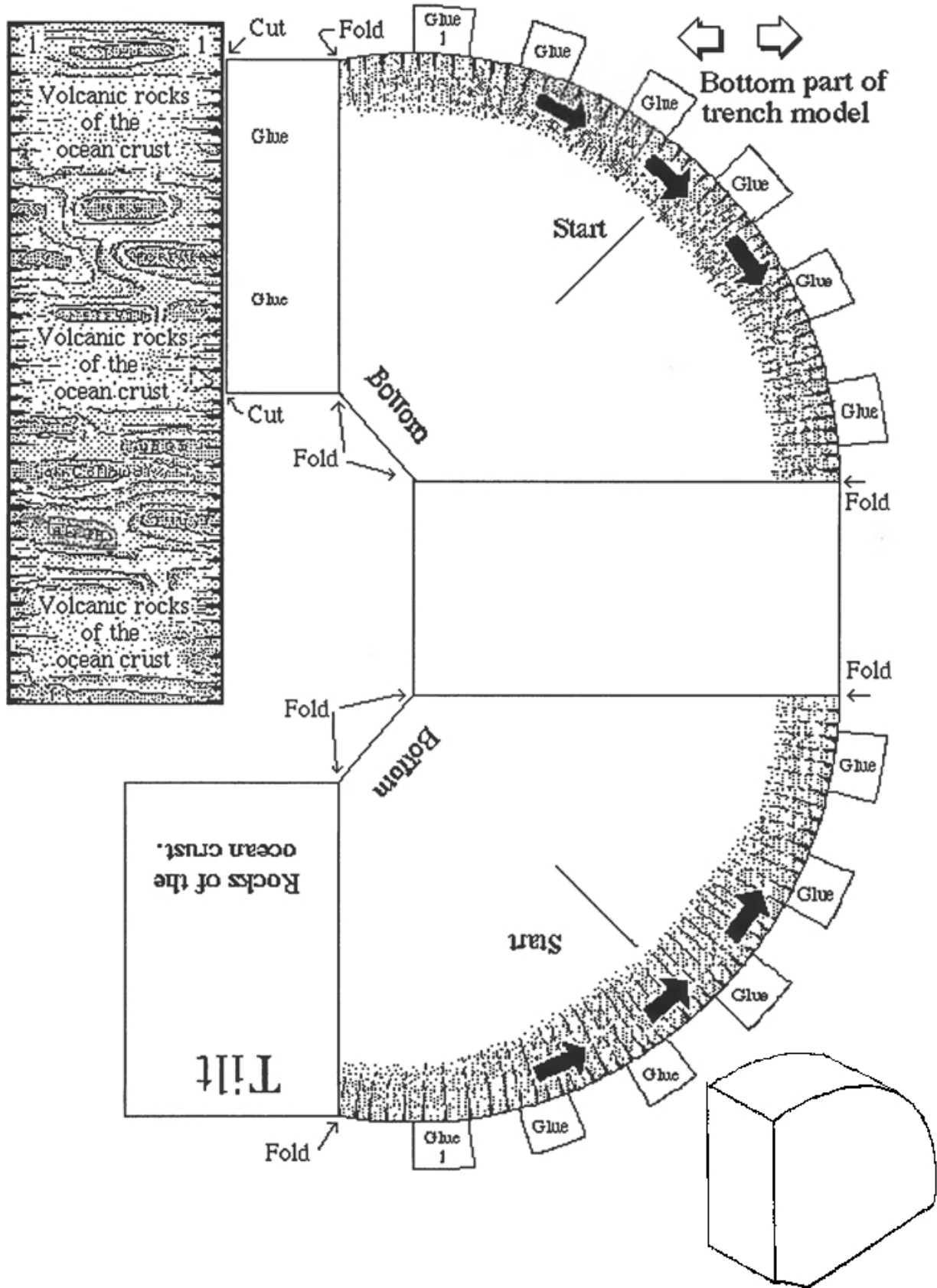

Name: _____

Subduction Zones Student Worksheet

Grades
5-8

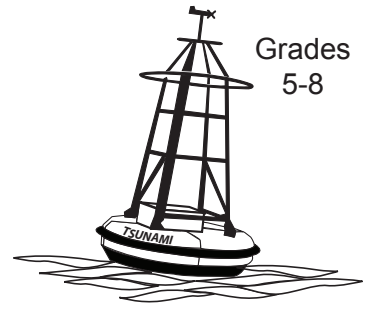

Word Bank		
continental crust	trench	oceanic crust
volcano	plate margin	zone of melting

1. Label the diagram below with words from the word bank.

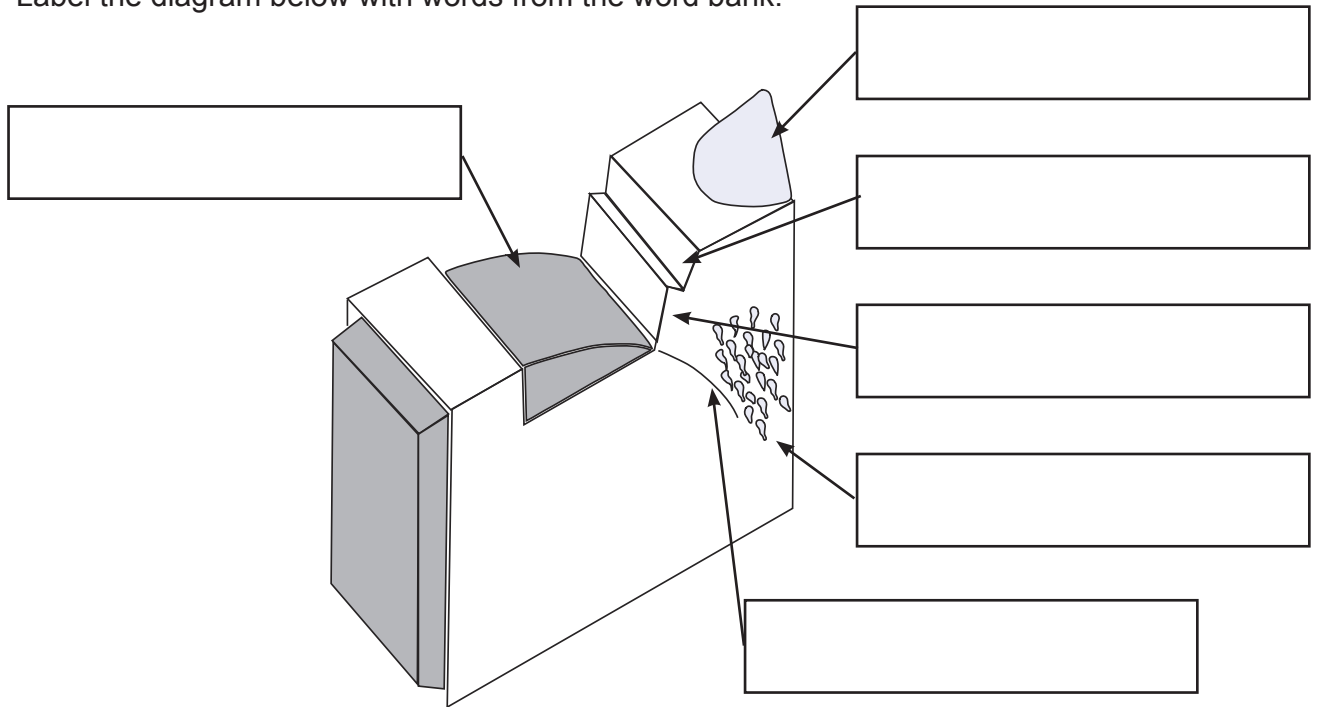

2. Explain how a subduction zone earthquake generates a tsunami.
